

PRODUCT INTRODUCTIONS 2024

SLT
T O O L S

P+K

N

M+S

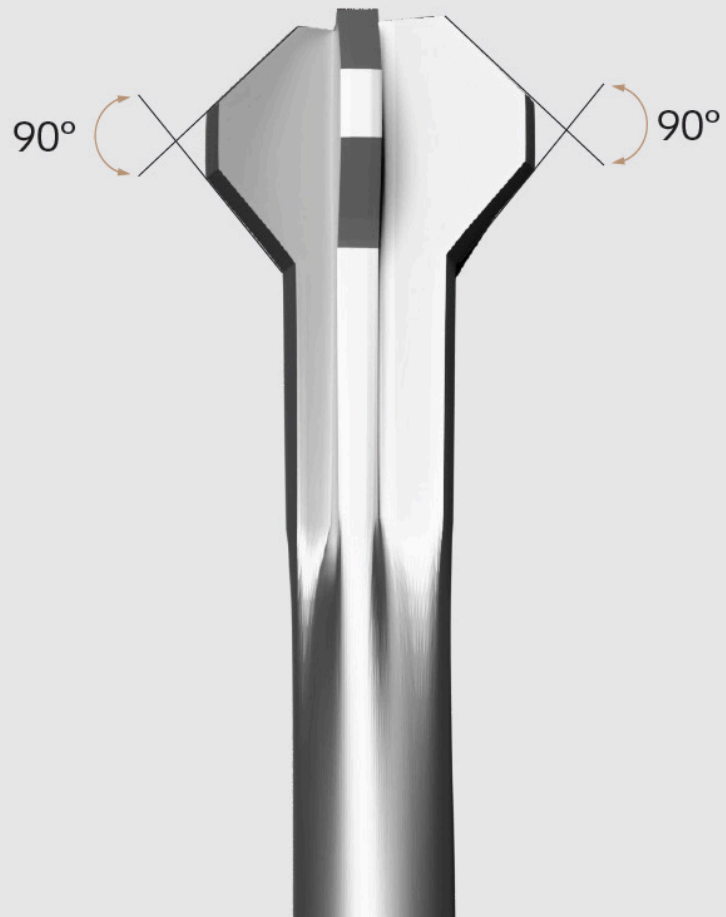

z = 5

Up and down
chamfering end mill 45°

Suitability for ISO-P+K, N, M+S

z=5 chamfering 45°

Up and down chamfering end mill | Suitability for ISO-P&K, N, M+S



Article		Dc	Ds	Lc	Ln	Dn	Lt	c	z	Coating	€
HA	HB										
BLC5X040A90N	-	4	4	1,0	16	2	54	45°	5	AlCrN	108,72
BLC5X060A90N	-	6	6	1,5	24	3	62	45°	5	AlCrN	124,54
BLC5X080A90N	-	8	8	1,5	32	5	70	45°	5	AlCrN	143,55
BLC5X100A90N	-	10	10	1,5	40	7	82	45°	5	AlCrN	173,03
BLC5X120A90N	-	12	12	2,0	48	8	95	45°	5	AlCrN	215,93

P+K



z=7 38VN

Up to 3xD

- MRR (Q) up to 140%*
- Steel and cast iron machining

z=7 38VN

z=7 up to 3xD | MRR (Q) up to 140%* | Steel and cast iron machining

P+K

Article		Dc	Ds	Lc	Ln	Dn	Lt	c	z	Coating	€
HA	HB										
BLC7X03038VN	BLW7X03038VN	3,0	6	9	14	2,8	62	0,06	7	AlCrN	47,65
BLC7X04038VN	BLW7X04038VN	4,0	6	12	18	3,8	62	0,08	7	AlCrN	47,65
BLC7X05038VN	BLW7X05038VN	5,0	6	15	21	4,8	62	0,10	7	AlCrN	47,65
BLC7X06038VN	BLW7X06038VN	6,0	6	18	24	5,7	62	0,12	7	AlCrN	47,65
BLC7X08038VN	BLW7X08038VN	8,0	8	24	30	7,6	68	0,16	7	AlCrN	63,50
BLC7X10038VN	BLW7X10038VN	10,0	10	30	38	9,5	80	0,20	7	AlCrN	92,38
BLC7X12038VN	BLW7X12038VN	12,0	12	36	46	11,5	93	0,24	7	AlCrN	124,98
BLC7X14038VN	BLW7X14038VN	14,0	14	42	50	13,5	100	0,28	7	AlCrN	166,17
BLC7X16038VN	BLW7X16038VN	16,0	16	48	58	15,5	108	0,32	7	AlCrN	223,49
BLC7X18038VN	BLW7X18038VN	18,0	18	54	67	17,5	115	0,36	7	AlCrN	285,75
BLC7X20038VN	BLW7X20038VN	20,0	20	60	74	19,5	126	0,40	7	AlCrN	348,95
BLC7X25038VN	BLW7X25038VN	25,0	25	75	92	24,0	150	0,50	7	AlCrN	611,50

* in comparison to BLC5Xxxx38VN

M+S



z=7 42VN

Up to 3xD

- MRR (Q) up to 140%*
- Stainless steel and titanium machining

z=7 42VN

z=7 up to 3xD | MRR (Q) up to 140%* | Stainless steel and titanium machining

M+S

Article		Dc	Ds	Lc	Ln	Dn	Lt	c	z	Coating	€
HA	HB										
BLC7X03042VN	BLW7X03042VN	3,0	6	9	14	2,8	62	0,06	7	AlCr	51,31
BLC7X04042VN	BLW7X04042VN	4,0	6	12	18	3,8	62	0,08	7	AlCr	51,31
BLC7X05042VN	BLW7X05042VN	5,0	6	15	21	4,8	62	0,10	7	AlCr	51,31
BLC7X06042VN	BLW7X06042VN	6,0	6	18	24	5,7	62	0,12	7	AlCr	51,31
BLC7X08042VN	BLW7X08042VN	8,0	8	24	30	7,6	68	0,16	7	AlCr	65,97
BLC7X10042VN	BLW7X10042VN	10,0	10	30	38	9,5	80	0,20	7	AlCr	98,00
BLC7X12042VN	BLW7X12042VN	12,0	12	36	46	11,5	93	0,24	7	AlCr	131,08
BLC7X14042VN	BLW7X14042VN	14,0	14	42	50	13,5	100	0,28	7	AlCr	182,98
BLC7X16042VN	BLW7X16042VN	16,0	16	48	58	15,5	108	0,32	7	AlCr	245,49
BLC7X18042VN	BLW7X18042VN	18,0	18	54	67	17,5	115	0,36	7	AlCr	305,98
BLC7X20042VN	BLW7X20042VN	20,0	20	60	74	19,5	126	0,40	7	AlCr	382,43
BLC7X25042VN	BLW7X25042VN	25,0	25	75	92	24	150	0,50	7	AlCr	665,79

* in comparison to BLC5Xxxx42VN



www.sct-tools.com | sales@sct-tools.com | +31(0)13 531 0080